



CIE India

Europe

2023

Index



CIE India

1. CIE Overview
2. Europe Overview
3. Plants Summary
4. Products
5. Quality



1 CIE Overview

Who we are

CIE India is a subsidiary of CIE Automotive.

CIE India SHAREHOLDING

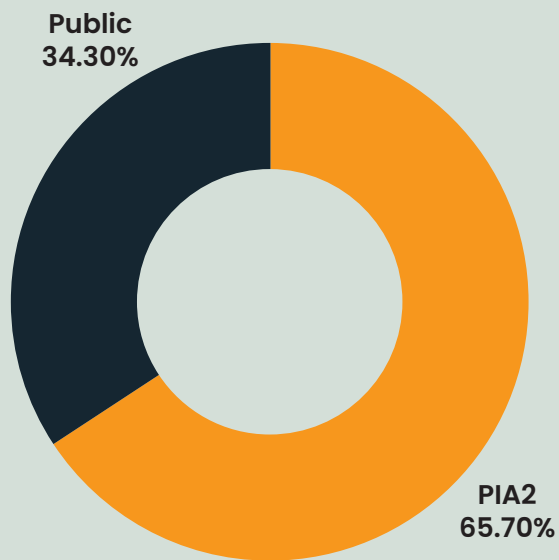

CIE India is listed on BSE and NSE in India.



33 plants and 13,000 + professionals, producing components in various countries and in various technologies.



- FORGING
- CASTING
- STAMPING
- MACHINING
- ALUMINIUM
- MAGNETS
- COMPOSITES

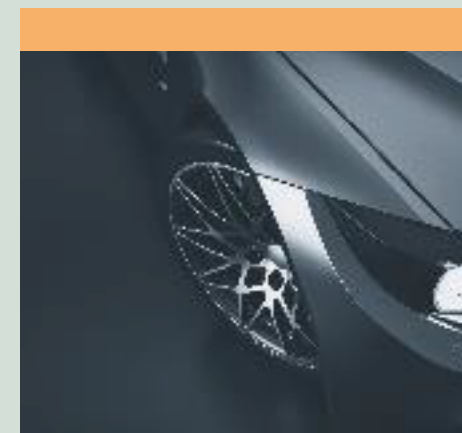

CIE India Global

Geographical distribution



CIE India Presence

Plant location



CIE India in Europe

Plant location

● CIE FORGING SPAIN AND LITHUANIA

- 3 Plants
- **Focused on Passenger Vehicles**

● METALCASTELLO (GEARS, ITALY)

- 1 Plant
- **Focused on Off-Highway & Agriculture**

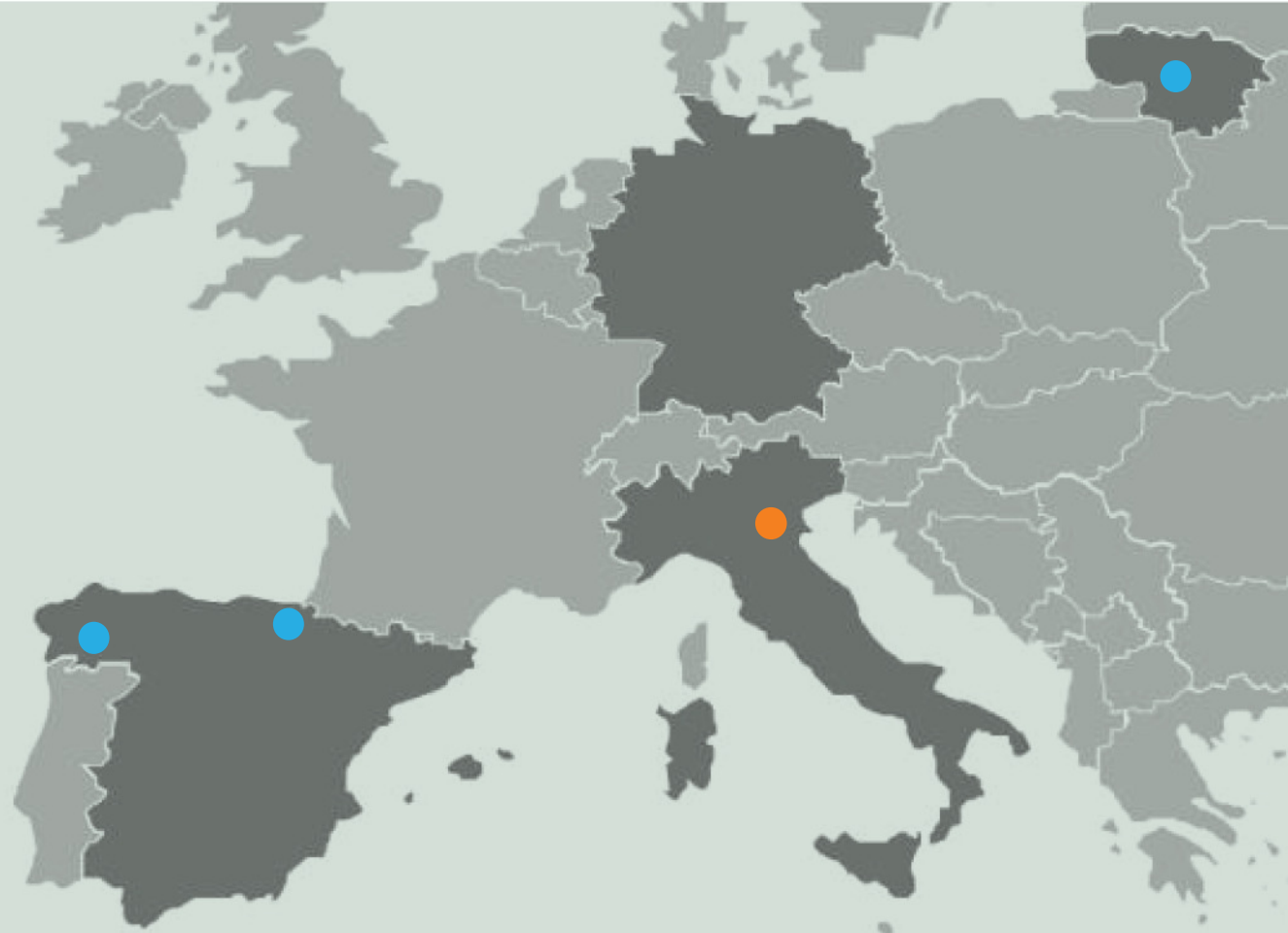

Global Customer List

BAJAJ

KOBENSCHMIDT

BOSCH

MAHINDRA

CAT

MAN

DAIMLER

MARUTI

FIAT

NEXTEER

FORD

NIDEC

GKN

NTN

HERO

RENAULT

HYUNDAI

SAF

JLR – TATA

VOLKSWAGEN



2

Europe
Overview

EUROPE

European plants

● SPAIN

CIE GALFOR

Turnover 2021:

- CRANKSHAFTS
- FRONT AXLE BEAMS
- AXLE ENDS
- AXLE SHAFTS
- STEERING KNUCKLES
- ALUMINIUM FORGING

● LITHUANIA

CIE LT FORGE

Turnover 2021:

- CRANKSHAFTS
- TULIPS, OUTER RACES & STUBS
- FLANGE SHAFTS
- DIFFERENTIAL CROWNS
- PINION SHAFTS
- EXHAUST SYSTEM FLANGES
- FUEL BODY PUMPS

CIE LEGAZPI

Turnover 2021:

- TULIPS, OUTER RACES & STUBS
- FLANGE SHAFTS
- DIFFERENTIAL CROWNS
- PINION SHAFTS
- STEERING SECTOR SHAFTS
- AXLE SHAFTS
- INPUT SHAFTS

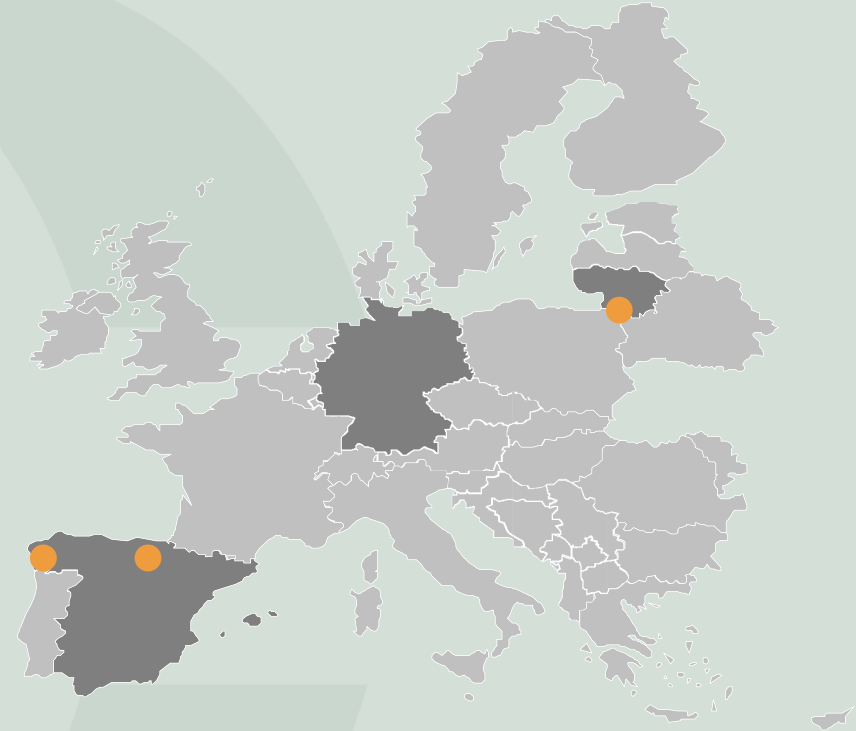



3 Plants Summary

Who we are



Ourense, Spain.

Surface:
25.500m²

Employees:
350



Processes:

- Forging
- Tooling Shop
- Heat Treatment & Finishing

Range of Machines:

- Vertical Forging: 5 Presses, 4.000 to 6.300 Tn.
- Hammer Line
- Electro- Upsetter Line
- Extrusion Line

Products:

100% Automotive

Passenger Cars (Engine)

Crankshafts



Passenger Cars & LCV (Chassis)

Aluminum Supports

Aluminum Control & Steering arms



Commercial Vehicles (Powertrain)

Commercial Vehicles (Chassis)

Axle ends

Axle shafts

Steering Knuckles

Battery box components

Front Axle beams



Who we are



Legazpi, Spain.

Surface:
25.000m²

Employees:
245

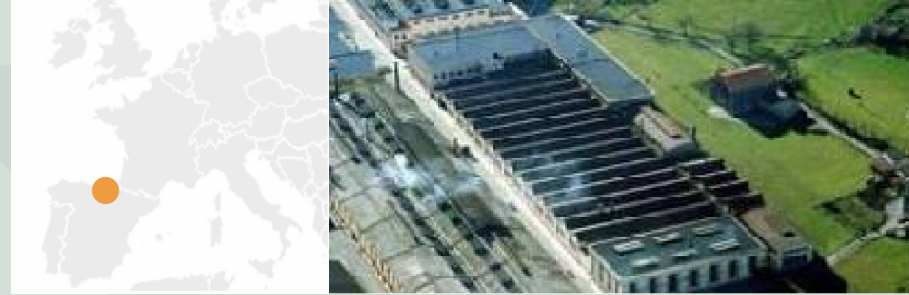

Processes:

- Forging
- Tooling Shop
- Heat Treatment & Finishing

Range of Machines:

- Vertical Forging: 14 Presses, 700 to 3.150 Tn.
- Cold Calibrating: 5 Presses
- Upsetting: 4 Presses, 450 to 1.230 Tn.

Products:

100% Automotive

Passenger Cars (Gearbox + Differential)

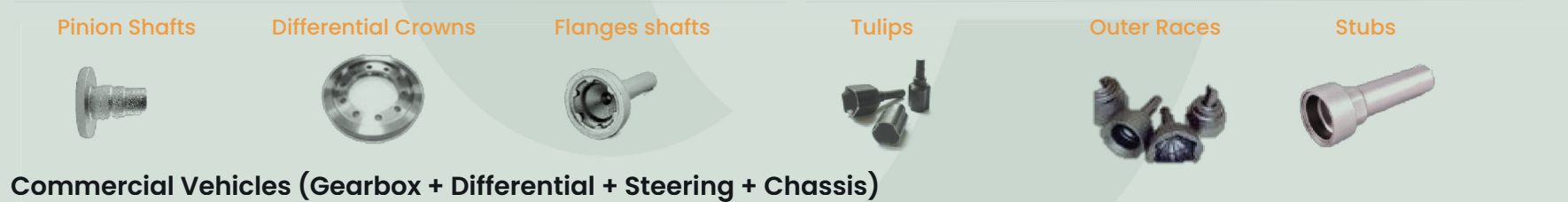

Commercial Vehicles (Gearbox + Differential + Steering + Chassis)



Who we are



Marijampole, Lithuania.

Surface:
13.000m²

Employees:
240

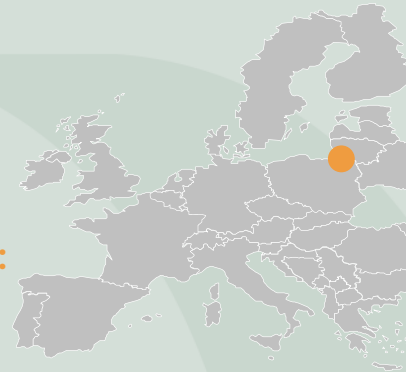

Processes:

- Forging
- Tooling Shop
- Machining
- Heat Treatment & Finishing

Range of Machines:

- Vertical Forging: 7 Presses, 1.600 to 5.000 Tn.
- Machining: 17 CNCs & 2 induction hardening

Products:

100% Automotive

Engine

Crankshafts



Injection Body Pump



Hybrid Hubs



Exhaust System Flanges



Gearbox

Driveline

Commercial Vehicles

Differential Crowns



Retarder Shaft



Pinion Shaft



Companion flanges & Flange shafts



Tulips & Outer Races



Stubs



King Pins



CUSTOMERS PASSENGER CARS & LCV

VOLKSWAGEN

AUDI

BMW

STELLANTIS

KIA

FORD

RENAULT NISSAN

BRP

JAGUAR

LANDROVER

MAHINDRA

MCLAREN

DAIMLER

TRIUMPH

GM

HONDA

GKN AUTOMOTIVE

NEAPCO

NEXTEER

NTN

LEAX

MAGNA

BOSCH

ZF

LINAMAR

FAURECIA

BORGWARNER

TENNECO

STREPARAVA

MAGNETI MARELLI









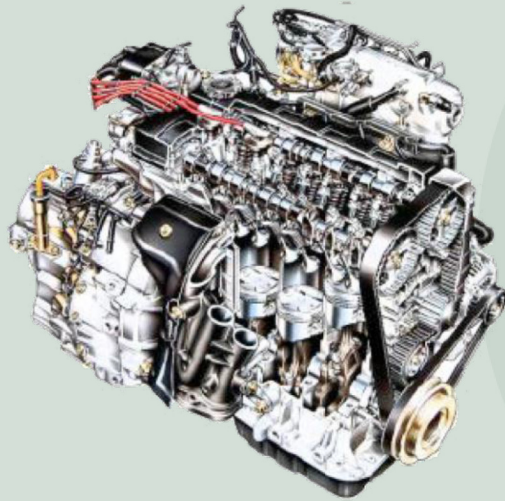

4
Products

PRODUCTS PASSENGER CARS & LCV

ENGINE









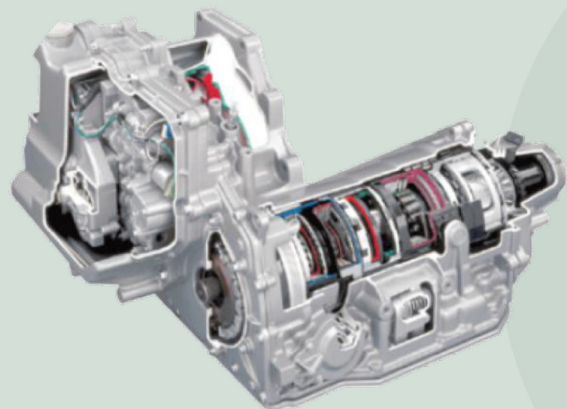

 CRANKSHAFT FORGING	 CRANKSHAFT FORGING	 INJECTION BODY PUMPS FORGING MACHINING	 EXHAUST FLANGES FORGING MACHINING
 HYBRID HUBS FORGING MACHINING	 HYBRID HUBS FORGING MACHINING	 ROTORS FORGING MACHINING	 ROTORS FORGING

PRODUCTS PASSENGER CARS & LCV

GEARBOX & REDUCTOR & E-DRIVE TRANSMISSION



 <p>PINION SHAFTS FORGING PRE MACHINING</p>	 <p>INTERMEDIATE SHAFTS FORGING PRE MACHINING</p>	 <p>DIFFERENTIAL CROWNS FORGING PRE MACHINING</p>	 <p>DIFFERENTIAL CROWNS FORGING PRE MACHINING</p>
 <p>CVT COMPONENTS FORGING PRE MACHINING</p>	 <p>FLANGE SHAFTS FORGING MACHINING</p>	 <p>FLANGE SHAFTS FORGING PRE MACHINING</p>	 <p>REDUCTOR FIXED GEARS FORGING PRE MACHINING</p>

PRODUCTS PASSENGER CARS & LCV

DRIVELINE



FLANGE SHAFTS
FORGING
PRE MACHINING



OUTER RACES
FORGING
PRE MACHINING



TULIPS
FORGING
PRE MACHINING



COMPANION FLANGES
FORGING
MACHINING









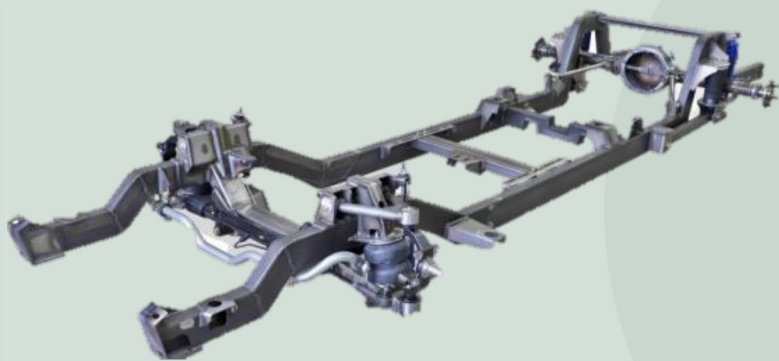

STUBS
FORGING
PRE MACHINING

PRODUCTS PASSENGER CARS & LCV

CHASSIS STEEL & ALUMINUM



 <p>BATTERY BOX COMPONENTS FORGING MACHINING</p>	 <p>WHEEL HUBS & SPINDLES FORGING</p>	 <p>KNUCKLES FORGING MACHINING</p>	 <p>CONTROL ARMS FORGING MACHINING</p>
	 <p>FLANGES FORGING MACHINING</p>	 <p>AXLE SHAFTS FORGING MACHINING</p>	
 <p>FRONT KNUCKLES ALU FORGING MACHINING</p>	 <p>BUMPER SUPPORT ALU FORGING MACHINING</p>	 <p>FRONT KNUCKLES ALU FORGING MACHINING</p>	 <p>WHEEL CARRIERS & CONTROL ARMS ALU FORGING MACHINING</p>



5
Quality

Certifications

OUR PLANTS ARE CERTIFIED: IAT 16949, ISO 14001 & ISO 45001

Bureau Veritas Certification



CIE LEGAZPI SA
CI UROLA 10-20230-LEGAZPI-GUIPÚZCOA-ESPAÑA

Bureau Veritas Certification Holding SAS – UK Branch certifica que el Sistema de Gestión de la organización indicada ha sido auditado y se encuentra conforme a los requisitos de las normas de gestión siguientes

ISO 45001:2018
Alcance de certificación

DISEÑO Y FABRICACIÓN DE PIEZAS FORJADAS (CALIENTE Y SEMICALIENTE) PARA LA INDUSTRIA DE AUTOMOCIÓN.

Fecha de certificación original	10-08-2020
Fecha de caducidad del ciclo anterior:	06-06-2021
Fechas de auditoria de certificación / recertificación:	24-05-2021
Fecha de inicio del ciclo de certificación / recertificación:	07-06-2021

Sujeto a un funcionamiento continuo y satisfactorio del Sistema de Gestión de la organización, este certificado caduca el: **06-06-2024**

Nº Certificado ES121320 **Versión :** Nº 1 **Fecha de revisión:** 31-05-2021

Dirección de la Entidad de Certificación: 8th Floor, 66 Prescot Street, London E1 8HG, United Kingdom
Dirección Oficina Local: C/Valporiello Primera 22-24, Edificio Caoba, 28108 Alcobendas, Madrid, Spain





Información adicional sobre el alcance y validez de este certificado y la aplicación de los requisitos del sistema de gestión, pueden obtenerse consultando a la organización. Para confirmar la validez de este certificado, por favor contacte en el número +34912702200
UKAS Certificado Plantilla Single Site Rev.3.8 14 Diciembre 2020
1 / 1



Certificate of Approval
Awarded to
CIE GALFOR SAU

Pol. Ind. San Cibrao das Viñas, Calle 2 - 32901 - Ourense - ESPAÑA

Bureau Veritas Certification certify that the Quality Management System of the above organisation has been audited and found to be in accordance with the requirements of

IATF 16949 - First Edition
and the applicable customer specific requirements



SCOPE

Design and manufacturing

PERMITTED EXCLUSION(S)

None

PRODUCT(S) DELIVERED

HOT FORGING AND HEAT TREATMENT OF CARBON AND ALLOY STEEL PARTS

Date Of Certification: 20-12-2021

Date Of Expiration: 19-12-2024

IATF Certificate N°: 438777

Bureau Veritas Certification Certificate N°: SPA-22554/1- IATF *Revision:1*



For Bureau Veritas Certification Holding, Le Triangle de l'Arche, 8 Cours du Triangle - 92800 Puteaux - France
(The official document is in English. Any translations of this document shall be used for reference only.)



CIE LT FORGE
STOTIES G 12-LT 4520-MARIJAMPOLE-LITUANIA

Bureau Veritas Certification Holding SAS – UK Branch certifies that the Management System of the above organisation has been audited and found to be in accordance with the requirements of the management system standards detailed below

ISO 14001:2015
Scope of certification

FORGED AND MACHINED PARTS FOR THE AUTOMOTIVE INDUSTRY.

Original cycle start date/ Original cycle start date by previous certification body:	21-01-2010
Expiry date of previous cycle:	12-08-2021
Certification Audit date / Recertification Audit date:	20-07-2021
Certification cycle start date / Recertification cycle start date:	13-08-2021

Subject to the continued satisfactory operation of the organization's Management System, this certificate expires on: **12-08-2024**

Certificate N°: ES123309 **Version :** Nº. 1 **Issue date:** 26-07-2021

Certification body address: 8th Floor, 66 Prescot Street, London E1 8HG, United Kingdom
Local office: C/Valporiello Primera 22-24, Edificio Caoba, 28108 Alcobendas, Madrid, Spain





Further clarifications regarding the scope and validity of this certificate and the applicability of the management system requirements, can be obtained by consulting the organization. To confirm the validity of this certificate, please contact the number +34912702200

UKAS Certificate Template single site rev 3.9 1 / 1 June 24, 2021

MCIE in Europe

Evolution

**OUR FOCUS
IS TO
KEEP GROWING
AT
HIGH PACE IN
INDIA
IN
COMING YEARS**

- Investment Capacity
- Organic Growth
- Greenfields & Acquisitions
- CIE Technology Transfer
- New Products introduction
- Increasing Exports
- Engineering Co-Development
- Global Automotive Market State-of-the-Art Technology
- Global Platform support



CIE India

THANK YOU